

SN75970B SCSI DIFFERENTIAL CONVERTER-CONTROL

SLLS323A – NOVEMBER 1999 – REVISED JANUARY 2000

- Provides High-Voltage Differential SCSI from Single-Ended Controller When Used With the SN75971B Data Transceiver
- Nine Transceivers Meet or Exceed the Requirements of ANSI Standard EIA-485 and ISO-8482 Standards
- ESD Protection on Bus Pins to 12 kV
- Packaged in Shrink Small-Outline Package with 25 mil Terminal Pitch and Thin Small-Package with 20 mil Terminal Pitch
- Low Disabled Supply Current 32 mA Typ
- Thermal Shutdown Protection
- Positive- and Negative-Current Limiting
- Power-Up/-Down Glitch Protection
- Open-Circuit Failsafe Receivers

description

The SN75970B SCSI differential converter-control, when used in conjunction with one or more of its companion data transceiver(s), provides the superior electrical performance of differential SCSI from a single-ended SCSI bus controller. A 16-bit, Fast-SCSI bus can be implemented with just three devices (two for data and one for control) in the space-efficient, 56-pin, shrink small-outline package (SSOP) as well as the even smaller TSSOP and a few external components.

The SN75970B is available in a B2 (20 Mxfer) version and a B1 (10 Mxfer) version.

In a typical differential SCSI node, the SCSI controller provides the enables for each external RS-485 transceiver. This could require as many as 27 additional terminals for a 16-bit differential bus controller or relegate a 16-bit single-ended controller to only an 8-bit differential bus. Using the standard nine SCSI control signals, the SN75970B control transceiver decodes the state of the bus and enables the SN75971B data transceiver(s) to transmit the single-ended SCSI input signals differentially to the cable or receive the differential cable signals and drive the single-ended outputs to the controller.

The single-ended SCSI bus interface consists of CMOS bidirectional inputs and outputs. The drivers are rated at ± 16 mA of output current. The receiver inputs are pulled high with approximately 4 mA to eliminate the need for external pullup resistors for the open-drain outputs of most single-ended SCSI controllers. The single-ended side of the device is not intended to drive the SCSI bus directly.

DGG OR DL PACKAGE
(TOP VIEW)

RSTFLTR	1	56	X2
RESET	2	55	X1/CLK20
DSSENS	3	54	NC
CLK40	4	53	BATN-
GND	5	52	BATN+
AATN-	6	51	BACK-
TEST	7	50	BACK+
AACK-	8	49	BREQ-
TIMEOUT	9	48	BREQ+
AREQ-	10	47	BC/D-
AC/D-	11	46	BC/D+
V _{CC}	12	45	V _{CC}
GND	13	44	GND
GND	14	43	GND
GND	15	42	GND
GND	16	41	GND
GND	17	40	GND
V _{CC}	18	39	V _{CC}
DRVBUS	19	38	BMSG-
SDB	20	37	BMSG+
AMSG-	21	36	BI/O-
AI/O-	22	35	BI/O+
ASEL-	23	34	BSEL+
NC	24	33	BSEL-
ABSY-	25	32	BBSY+
NC	26	31	BBSY-
ARST-	27	30	BRST+
NC	28	29	BRST-

NC – No internal connection
Terminals 13 through 17 and 40 through 44 are connected together to the package lead frame and signal ground.



Please be aware that an important notice concerning availability, standard warranty, and use in critical applications of Texas Instruments semiconductor products and disclaimers thereto appears at the end of this data sheet.

PRODUCTION DATA information is current as of publication date. Products conform to specifications per the terms of Texas Instruments standard warranty. Production processing does not necessarily include testing of all parameters.

**TEXAS
INSTRUMENTS**

POST OFFICE BOX 655303 • DALLAS, TEXAS 75265

Copyright © 2000, Texas Instruments Incorporated

SN75970B SCSI DIFFERENTIAL CONVERTER-CONTROL

SLLS323A – NOVEMBER 1999 – REVISED JANUARY 2000

description (continued)

The differential SCSI bus interface consists of bipolar bidirectional inputs and outputs that meet or exceed the requirements of EIA-485 and ISO 8482-1982/TIA TR30.2 referenced by the American National Standard of Information Systems (ANSI) X3.131-1994 Small Computer System Interface-2 (SCSI-2) and SCSI-3 Fast-20 Parallel Interface (Fast-20) X3.277:1996.

The SN75970B is characterized for operation over the temperature range of 0°C to 70°C.

The SN75970B consists of nine RS-485 differential transceivers, nine TTL- or CMOS-level compatible transceivers, a state machine and control logic block, a 20-MHz crystal-controlled oscillator, a timer, a power-up/down glitch protection circuit, and a thermal-shutdown protection circuit.

The single-ended or controller interface is designated as the A side and the differential port is the B side. Since the device uses the SCSI control signals to decode the state of the bus and data flow direction, the terminal assignments must be matched to the corresponding signal on the SCSI bus. The signal name followed by a minus sign (-) indicates an active-low signal while a plus sign (+) indicates an active-high signal.

A reset function, which disables all outputs and clears internal latches, can be accomplished from two external inputs and two internally generated signals. $\overline{\text{RESET}}$ (Reset) and DSENS (differential sense) are available to external circuits for a bus reset or to disable all outputs should a single-ended cable be inadvertently connected to a differential connector. The power-up and thermal-shutdown are internally generated signals that have the same effect when the supply voltage is below 3.5 V or the junction temperature exceeds approximately 175°C.

This data sheet contains descriptions of the SN75970B input and output signals followed by the electrical characteristics. The parameter measurement information is followed by the theory of operation, a state flow chart, and a typical circuit in the application information section.

logic diagram (positive logic)

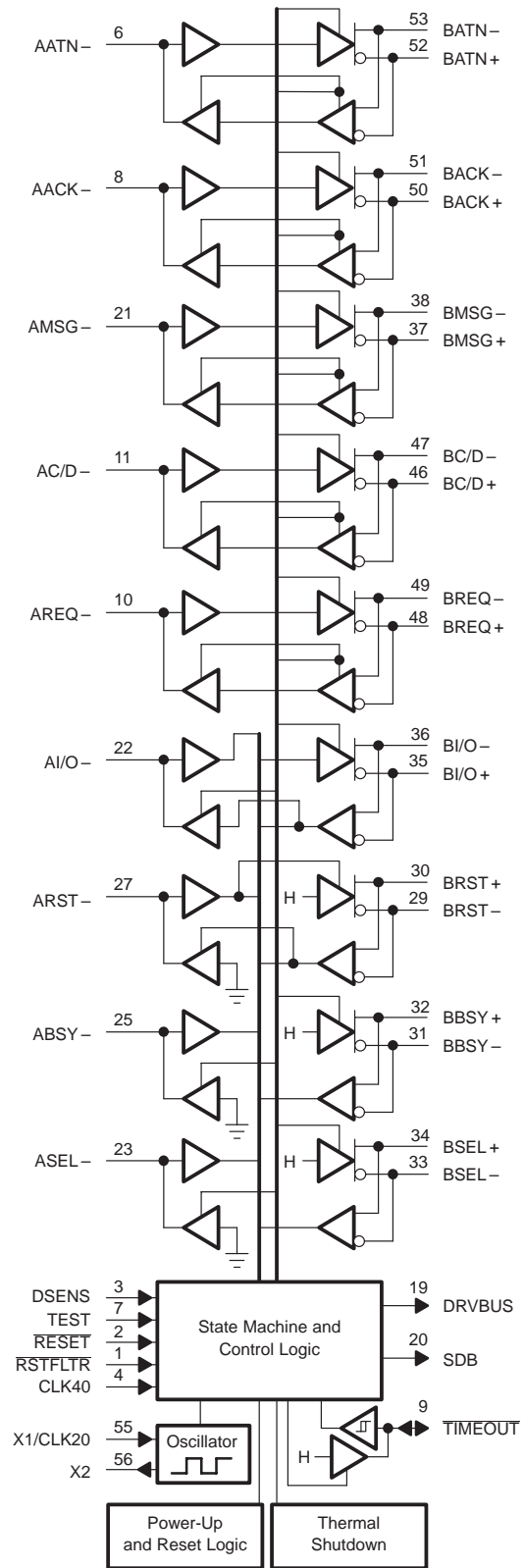

SN75970B SCSI DIFFERENTIAL CONVERTER-CONTROL

SLLS323A – NOVEMBER 1999 – REVISED JANUARY 2000

Terminal Functions

TERMINAL NAME	NO.	LOGIC LEVEL	I/O	TERMINATION	DESCRIPTION
AACK–	8	TTL	I/O	strong pullup	SCSI acknowledge (–ACK) signal to/from controller
AATN–	6	TTL	I/O	strong pullup	SCSI attention (–ATN) signal to/from controller
ABSY–	25	TTL	I/O	strong pullup	SCSI busy (–BSY) signal to/from the controller
AC/D–	11	TTL	I/O	strong pullup	SCSI control/data (–C/D) signal to/from the controller
AI/O–	22	TTL	I/O	strong pullup	SCSI input/output (–I/O) signal to/from the controller
AMSG–	21	TTL	I/O	strong pullup	SCSI message (–MSG) signal to/from the controller
AREQ–	10	TTL	I/O	strong pullup	SCSI request (–REQ) signal to/from controller
ARST–	27	TTL	I/O	strong pullup	SCSI reset (–RST) signal to/from the controller
ASEL–	23	TTL	I/O	strong pullup	SCSI select (–SEL) signal to/from the controller
BACK–	51	RS-485	I/O	weak pullup	SCSI acknowledge (–ACK) signal to/from the bus
BACK+	50	RS-485	I/O	weak pulldown	SCSI acknowledge (+ACK) signal to/from the bus
BATN–	53	RS-485	I/O	weak pullup	SCSI attention (–ATN) signal to/from the bus
BATN+	52	RS-485	I/O	weak pulldown	SCSI attention (+ATN) signal to/from the bus
BBSY–	31	RS-485	I/O	weak pulldown	SCSI busy (–BSY) signal to/from the bus
BBSY+	32	RS-485	I/O	weak pullup	SCSI busy (+BSY) signal to/from the bus
BC/D–	47	RS-485	I/O	weak pullup	SCSI control/data (–C/D) signal to/from the bus
BC/D+	46	RS-485	I/O	weak pulldown	SCSI control/data (+C/D) signal to/from the bus
BI/O–	36	RS-485	I/O	weak pullup	SCSI input/output (–I/O) signal to/from the bus
BI/O+	35	RS-485	I/O	weak pulldown	SCSI input/output (+I/O) signal to/from the bus
BMSG–	38	RS-485	I/O	weak pullup	SCSI message (–MSG) signal to/from the bus
BMSG+	37	RS-485	I/O	weak pulldown	SCSI message (+MSG) signal to/from the bus
BREQ–	49	RS-485	I/O	weak pullup	SCSI request (–REQ) signal to/from the bus
BREQ+	48	RS-485	I/O	weak pulldown	SCSI request (+REQ) signal to/from the bus
BRST–	29	RS-485	I/O	weak pulldown	SCSI reset (–RST) signal to/from the bus
BRST+	30	RS-485	I/O	weak pullup	SCSI reset (+RST) signal to/from the bus
BSEL–	33	RS-485	I/O	weak pulldown	SCSI select (–SEL) signal to/from the bus
BSEL+	34	RS-485	I/O	weak pullup	SCSI select (+SEL) signal to/from the bus
CLK40	4	CMOS	I	strong pulldown	40-MHz clock input
DRVBUS	19	TTL	O	N/A	Driver bus. A high-level logic signal that indicates the SCSI bus is in one of the information transfer phases.
DSENS	3	TTL	I	weak pullup	A low-level input initializes the internal latches and disables all drivers.
GND	5, 13–17, 40–44	N/A	N/A	N/A	Supply common
$\overline{\text{RESET}}$	2	TTL	I	weak pullup	Reset. A low-level input initializes the internal latches and disables all drivers.
$\overline{\text{RSTFLTR}}$	1	TTL	I	weak pullup	Reset filter. Filtered input from the SCSI bus for a system reset. $\overline{\text{RSTFLTR}}$ differs from $\overline{\text{RESET}}$ by keeping the ARST and BRST drivers enabled.
SDB	20	TTL	O	N/A	A high-level logic signal that indicates a differential to single-ended data flow.
TEST	7	TTL	I	weak pulldown	Test. A high-level input that places the device in a test mode (see Table 1). It is grounded during normal operation.
$\overline{\text{TIMEOUT}}$	9	Analog	I/O	N/A	Time out. This signal connects to an external RC time constant for a time out during bus arbitration.
V _{CC}	12, 18, 39, 45	N/A	N/A	N/A	5-V supply voltage
X1/CLK20	55	CMOS	I	none	20-MHz crystal oscillator or clock input
X2	56	Analog	O	none	20-MHz crystal oscillator feedback



SN75970B SCSI DIFFERENTIAL CONVERTER-CONTROL

SLLS323A – NOVEMBER 1999 – REVISED JANUARY 2000

schematics of inputs and outputs

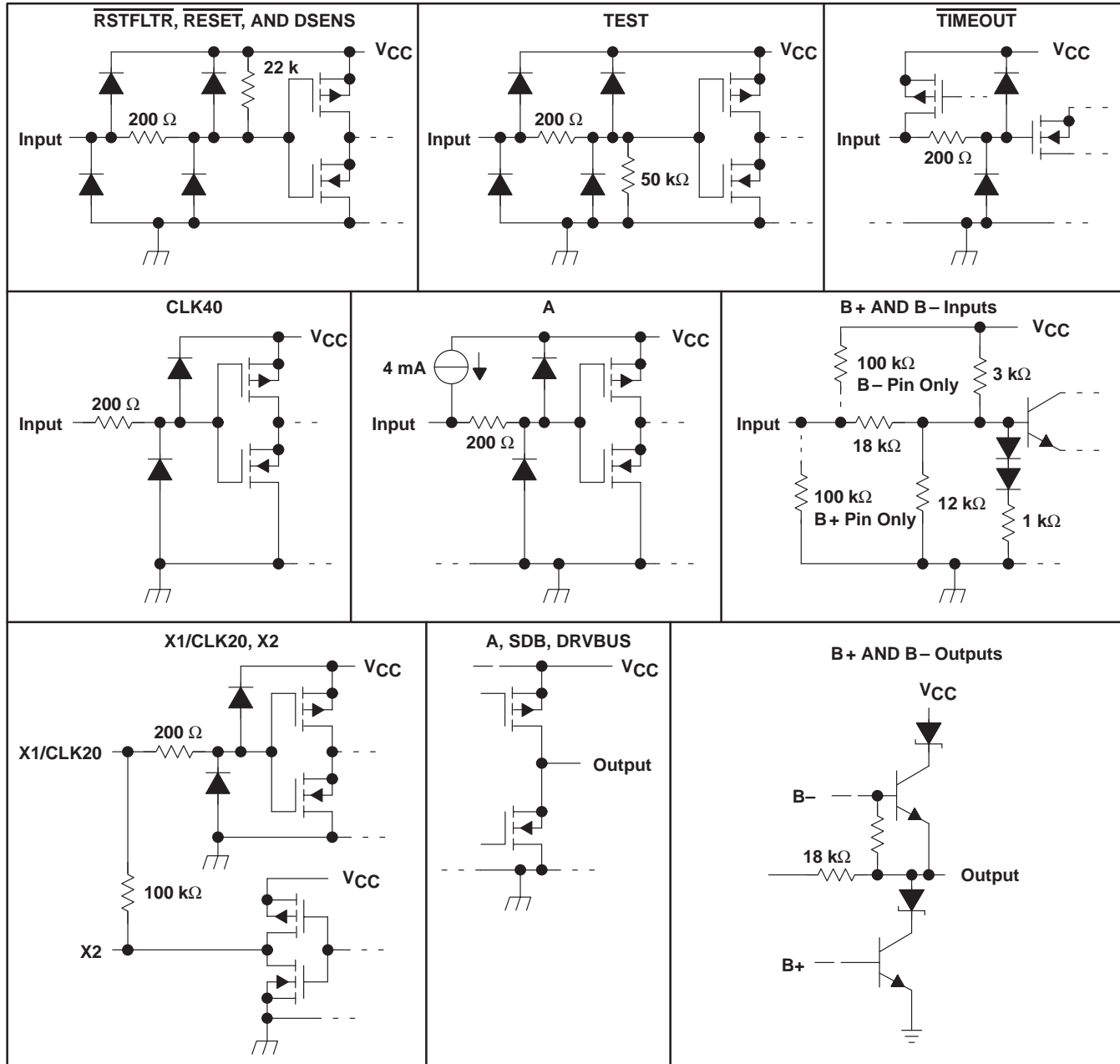

SN75970B SCSI DIFFERENTIAL CONVERTER-CONTROL

SLLS323A – NOVEMBER 1999 – REVISED JANUARY 2000

absolute maximum ratings over operating free-air temperature range (unless otherwise noted)†

Supply voltage range, V_{CC} (see Note 1)	–0.3 V to 6 V
Differential bus voltage range (B side)	–10 V to 15 V
Signal-ended bus voltage range (A side and control)	–0.3 V to 7 V
Continuous total power dissipation	See Dissipation Rating Table
Electrostatic discharge: B side (see Note 2): Class 3, A:	12 kV
Class 3, B:	400 V
All terminals: Class 2, A:	4 kV
Class 2, B:	400 V
Operating free-air temperature range, T_A	0°C to 70°C
Storage temperature range, T_{stg}	–65°C to 150°C
Lead temperature 1,6 mm (1/16 inch) from case for 10 seconds	260°C

† Stresses beyond those listed under “absolute maximum ratings” may cause permanent damage to the device. These are stress ratings only, and functional operation of the device at these or any other conditions beyond those indicated under “recommended operating conditions” is not implied. Exposure to absolute-maximum-rated conditions for extended periods may affect device reliability.

- NOTES: 1. All voltage values are with respect to the GND terminals.
2. This absolute maximum rating is tested in accordance with MIL-STD-883C, Method 3015.7.

DISSIPATION RATING TABLE

PACKAGE	$T_A \leq 25^\circ\text{C}$ POWER RATING	OPERATING FACTOR‡ ABOVE $T_A = 25^\circ\text{C}$	$T_A = 70^\circ\text{C}$ POWER RATING
DGG	3333 mW	26.7 mW/°C	2133 mW
DL	3709 mW	29.7 mW/°C	2374 mW

‡ This is the inverse of the traditional junction-to-case thermal resistance ($R_{\theta JA}$) for High-K (per JEDEC) PCB installations.

recommended operating conditions

		MIN	NOM	MAX	UNIT
Supply voltage, V_{CC}		4.75	5	5.25	V
High-level input voltage, V_{IH}	A side, \overline{DSENS} , \overline{TEST} , \overline{RESET} , and $\overline{RSTFLTR}$	2			V
	CLK40 AND X1/CLK20	$0.7 V_{CC}$			
Low-level input voltage, V_{IL}	A side, \overline{DENS} , \overline{TEST} , \overline{RESET} , and $\overline{RSTFLTR}$	0.8			V
	CLK40 AND X1/CLK20	$0.2 V_{CC}$			
Input voltage at any bus terminal (separately or common-mode), V_I	B side	12			V
		–7			
High-level output current, I_{OH}	A side, \overline{DRVBUS} , \overline{SDB} , $\overline{TIMEOUT}$	–16			mA
	X2	–4			
Low-level output current, I_{OL}	A side, \overline{DRVBUS} , and \overline{SDB}	16			mA
	X2	4			
Clock frequency, f_{CLK}	CLK20	20			MHz
	CLK40	40			
Operating case temperature, T_C		0		125	°C
Operating free-air temperature, T_A		0		70	°C



SN75970B

SCSI DIFFERENTIAL CONVERTER-CONTROL

SLLS323A – NOVEMBER 1999 – REVISED JANUARY 2000

electrical characteristics over recommended operating free-air temperature range (unless otherwise noted)

PARAMETER		TEST CONDITIONS	MIN	TYP†	MAX	UNIT	
V _{OD(H)}	Driver differential high-level output voltage	B side except BBSY, BRST, and BSEL	See Figure 1	-0.8	-2.2	V	
V _{OD(L)}	Driver differential low-level output voltage	B side		1	1.8	V	
V _{OH}	High-level output voltage	AACK-, AATN-, AC/D-, AI/O-, AMSG-, AREQ-	V _{ID} = -200 V, I _{OH} = -16 mA	2.5	4.3	V	
		DRVBUS, SDB	I _{OH} = -16 mA	2.5	4.4		
		<u>TIMEOUT</u>	Test and RESET at 0.8 V, All others open, I _{OH} = -16 mA	2.5	4.5		
		B side			3.4		
		X2	I _{OH} = -4 mA	3.2			
V _{OL}	Low-level output voltage	DRVBUS, SDB	I _{OL} = 16 mA		0.8	V	
		A side	V _{ID} = 200 mV, I _{OL} = 16 mA		0.8		
		B side			1.6		
		X2	I _{OL} = 4 mA		0.8		
V _{IT+}	Receiver positive-going input threshold voltage	B side	I _{OH} = -16 mA, See Figure 2		0.2	V	
		<u>TIMEOUT</u>			2.6		
V _{IT-}	Receiver negative-going input threshold voltage	B side	I _{OL} = 16 mA, See Figure 2	-0.2‡		V	
		<u>TIMEOUT</u>		0.32 V _{CC}	0.4 V _{CC}		
V _{hys}	Receiver input hysteresis (V _{IT+} - V _{IT-})	B side			45	mV	
		<u>TIMEOUT</u>		0.5		V	
I _I	Bus input current	B side	V _I = 12 V, V _{CC} = 5 V, All other inputs at 0 V	0.6	1	mA	
			V _I = 12 V, V _{CC} = 0, All other inputs at 0 V	0.7	1		
			V _I = -7 V, V _{CC} = 5 V, All other inputs at 0 V	-0.5	-0.8		
			V _I = -7 V, V _{CC} = 0, All other inputs at 0 V	-0.4	-0.8		
I _{IH}	High-level input current	A side	V _{IH} = 2 V	-2.0	-6	-8	mA
		DSENS, RESET, RSTFLTR		-60	-100		
		CLK40, X1/CLK20			±20		
		TEST			100		
		<u>TIMEOUT</u>	TEST at 2 V, A side and other control inputs at 0.8 V, B side open, V _{IH} = 2 V		±25	μA	

† All typical values are at V_{CC} = 5 V, T_A = 25°C.

‡ The algebraic convention with the least positive (more negative) limit is designated minimum, is used in this data sheet for the differential input voltage only.



SN75970B SCSI DIFFERENTIAL CONVERTER-CONTROL

SLLS323A – NOVEMBER 1999 – REVISED JANUARY 2000

electrical characteristics over recommended operating free-air temperature range (unless otherwise noted) (Continued)

PARAMETER		TEST CONDITIONS	MIN	TYP†	MAX	UNIT	
I _{IL}	A side	V _{IL} = 0.8 V	-6	-9		mA	
	DSENS, RESET, RSTFLTR				-100	μA	
	CLK40, X1/CLK20				±30		
	TEST				±30		
	TIMEOUT		TEST at 2 V, A side and other control inputs at 0.8 V, B side open, V _{IL} = 0.8 V				±25
I _{OS}	Short circuit output current	B side	V _O = 5 V and 0 V		±250	mA	
I _{CC}	Supply current	Disabled	RESET at 0.8 V, All others open		32	42	mA
		All A-side to B-side channels enabled	TEST and RSTFLTR at 2 V RESET at 0.8 V, All other inputs open, No load		72	95	
		All B-side to A-side channels enabled	TEST and B+ pins at 2 V, RESET, RSTFLTR, and B- pins at 0.8 V, All other inputs open, No load		51	72	
C _O	Bus output capacitance	B side to GND, V _I = 0.6 sin(2π 10 ⁶ t) + 1.5 V		18	21	pF	
C _{pd}	Power dissipation capacitance (see Note 3)	B side to A side, one channel		40		pF	
		A side to B side, one channel		100		pF	

† All typical values are at V_{CC} = 5 V, T_A = 25°C.

NOTE 3: C_{pd} determines the no-load dynamic current consumption, I_S = C_{pd} × V_{CC} × f + I_{CC} (I_{CC} depends upon the output states and load circuits and is not necessarily the same I_{CC} as specified in the electrical tables).



SN75970B

SCSI DIFFERENTIAL CONVERTER-CONTROL

SLLS323A – NOVEMBER 1999 – REVISED JANUARY 2000

switching characteristics over recommended operating free-air temperature range (unless otherwise noted)

PARAMETER		FROM (INPUT)	TO (OUTPUT)	TEST CONDITIONS	MIN	TYP†	MAX	UNIT
t_{d1}, t_{d2}	Delay time, A to B, high- to low-level or low- to high-level output	'B1	AATN– AC/D– AI/O– AMSG–	BATN± BC/D± BI/O± BMSG±	See Figure 3		3.5	17.7
							3.1	15.3
						$V_{CC} = 5\text{ V}, T_A = 25^\circ\text{C}$	4.2	12.2
		$V_{CC} = 5\text{ V}, T_A = 70^\circ\text{C}$	4.7	12.7				
	'B2	AATN– AC/D– AI/O– AMSG–	BATN± BC/D± BI/O± BMSG±	See Figure 3		5.5	15.7	
						4.5	13.3	
$V_{CC} = 5\text{ V}, T_A = 25^\circ\text{C}$					6.2	10.2		
	$V_{CC} = 5\text{ V}, T_A = 70^\circ\text{C}$	6.7	10.7					
$t_{sk(pp)}$	Skew, part-to-part	'B1	AACK– AREQ–	BACK± BREQ±	See Note 4		8	ns
		'B2	AACK– AREQ–	BACK± BREQ±	See Note 4		4	
$t_{sk(p)}$	Pulse skew	'B1	AACK– AREQ–	BACK± BREQ±	See Note 5		8	ns
		'B2	AACK– AREQ–	BACK± BREQ±	See Note 5		4	
t_{d3}, t_{d4}	Delay time, B to A, high- to low-level or low- to high-level output	'B1	BATN± BC/D± BI/O± BMSG±	AATN– AC/D– AI/O– AMSG–	See Figure 4		5.1	17.9
							5.3	18
						$V_{CC} = 5\text{ V}, T_A = 25^\circ\text{C}$	6.3	15.2
		$V_{CC} = 5\text{ V}, T_A = 70^\circ\text{C}$	6.7	15.6				
	'B2	BATN± BC/D± BI/O± BMSG±	AATN– AC/D– AI/O– AMSG–	See Figure 4		7.3	14.6	
						7.5	14.2	
$V_{CC} = 5\text{ V}, T_A = 25^\circ\text{C}$					8.5	13		
	$V_{CC} = 5\text{ V}, T_A = 70^\circ\text{C}$	8.9	13.4					
$t_{sk(pp)}$	Skew part-to-part	'B1	BACK± BREQ±	AACK– AREQ–	See Note 4		9	ns
		'B2	BACK± BREQ±	AACK– AREQ–	See Note 4		4.5	
$t_{sk(p)}$	Pulse skew	'B1	BACK± BREQ±	AACK– AREQ–	See Note 5		8	ns
		'B2	BACK± BREQ±	AACK– AREQ–	See Note 5		4	

† All typical values are at $V_{CC} = 5\text{ V}, T_A = 25^\circ\text{C}$.

NOTES: 4. Part-to-part skew is the magnitude of the difference in propagation delay times between any two devices when both operate with the same supply voltages, the same temperature, and the same loads.

5. Pulse skew is the difference between the high-to-low and low-to-high propagation delay times of any single channel.



SN75970B SCSI DIFFERENTIAL CONVERTER-CONTROL

SLLS323A – NOVEMBER 1999 – REVISED JANUARY 2000

switching characteristics over recommended operating free-air temperature range (unless otherwise noted) (continued)

PARAMETER		FROM (INPUT)	TO (OUTPUT)	TEST CONDITIONS	MIN	TYP†	MAX	UNIT
t _{PHL}	Delay time, high- to low-level	TIMEOUT	DRVBUS	See Figure 5			200	ns
t _{PLH}	Delay time, low- to high-level						200	ns
t _{dis}	Disable time	ABSY–	BBSY±	See Figure 6			200	ns
		ARST–	BRST±				200	
		ASEL–	BSEL±				200	
t _{en}	Enable time	ABSY–	BBSY±	See Figure 6			40	ns
		ARST–	BRST±				55	
		ASEL–	BSEL±				39	
t _{dis1}	Disable time	BRST±	ARST–	See Figure 7			93	ns
t _{dis2}	Disable time	BSEL±	ASEL–				55	ns
t _{dis3}	Disable time	BBSY±	ABSY–				60	ns
t _{en1}	Enable time	BRST±	ARST–				63	ns
t _{en2}	Enable time	BSEL±	ASEL–				45	ns
t _{en3}	Enable time	BBSY±	ABSY–				45	ns
t _{en4}	Enable time	BSEL±	ASEL–				92	ns

† All typical values are at V_{CC} = 5 V, T_A = 25°C.



SN75970B SCSI DIFFERENTIAL CONVERTER-CONTROL

SLLS323A – NOVEMBER 1999 – REVISED JANUARY 2000

PARAMETER MEASUREMENT INFORMATION

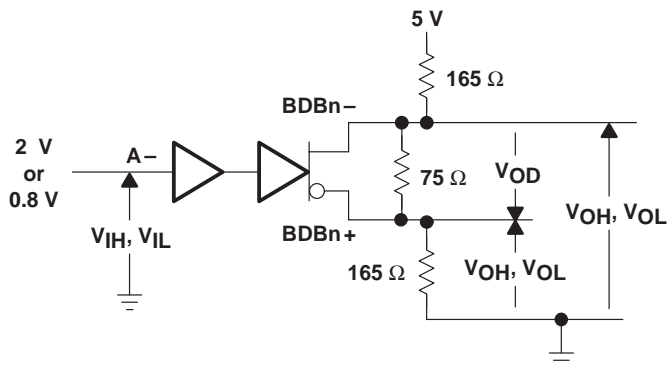

- NOTES: A. The input pulse is supplied by a generator having the following characteristics: $t_r \leq 3$ ns, $t_f \leq 3$ ns, $PRR \leq 1$ MHz, $45\% < \text{duty cycle} < 50\%$, $Z_O = 50 \Omega$.
 B. Resistance values are with a tolerance of 5%.
 C. All input voltage levels are held to within 0.01 V.

Figure 1. Differential Driver V_{OD} , V_{OH} , and V_{OL} Test Circuit

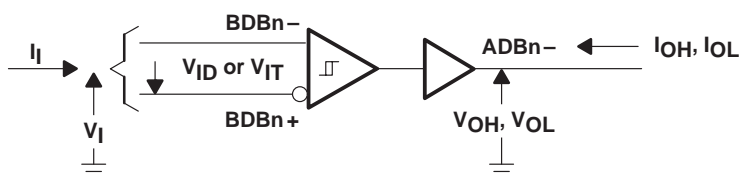
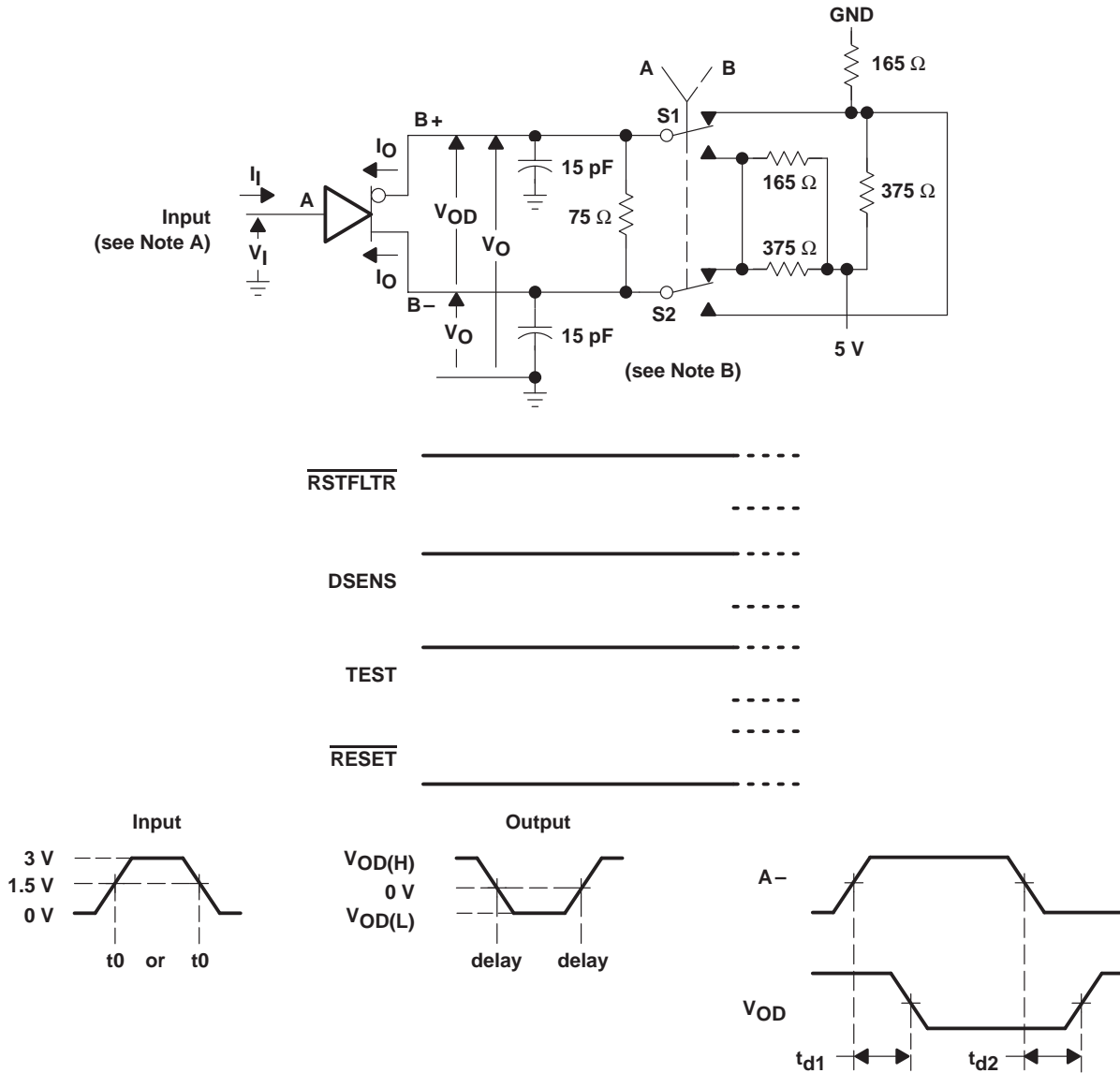

Figure 2. Single-Ended Driver V_{OD} , V_{OH} , and V_{OL} Test Circuit

PARAMETER MEASUREMENT INFORMATION



- NOTES: A. The input pulse is supplied by a generator having the following characteristics: $t_r \leq 1$ ns, $t_f \leq 1$ ns, $PRR \leq 1$ MHz, $45\% < \text{duty cycle} < 50\%$, $Z_O = 50 \Omega$.
 B. Resistance values are with a tolerance of $\pm 5\%$.
 C. All input voltage levels are held to within 0.01 V.

Figure 3. A-Side to B-Side Propagation Delay Time Test Circuit and Timing Definitions

SN75970B SCSI DIFFERENTIAL CONVERTER-CONTROL

SLLS323A – NOVEMBER 1999 – REVISED JANUARY 2000

PARAMETER MEASUREMENT INFORMATION

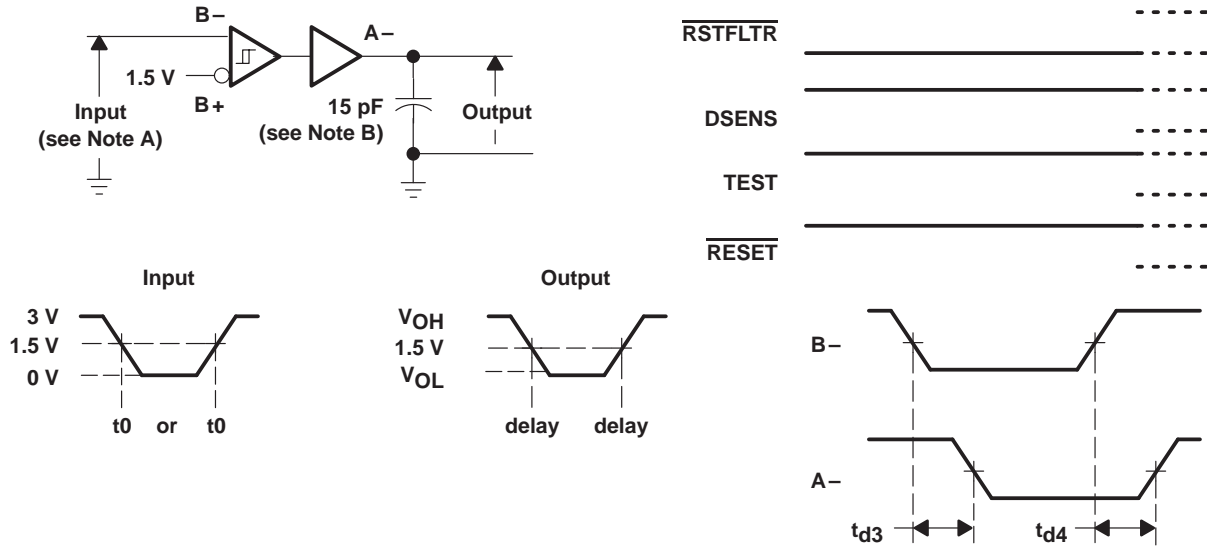

- NOTES: A. The input pulse is supplied by a generator having the following characteristics: $t_r \leq 1$ ns, $t_f \leq 1$ ns PRR ≤ 1 MHz, $45\% < \text{duty cycle} < 50\%$, $Z_O = 50 \Omega$.
 B. Resistance values are with a tolerance of $\pm 5\%$.
 C. All input voltage levels are held to within 0.01 V.

Figure 4. B-Side to A-Side Propagation Delay Time Test Circuit and Timing Definitions

Table 1. Output Test Enabling (No Clock Input)

SIGNAL	BUS		CONTROL INPUT(s)						
	INPUT(s)	OUTPUT	TEST	$\overline{\text{RSTFLTR}}$	$\overline{\text{RESET}}$	BBSY-	BBSY+	ABSYS-	DSENS
ATN, ACK, MSG, C/D, REQ, I/O	A	B	H	H	L				
ATN, ACK, MSG, C/D, REQ, I/O	B	A	H	L	L				
RST	A	B			L \rightarrow H	H	L	H	H
RST	B	A			L \rightarrow H	H	L	H	H
SEL, BSY	B	A	L	H	L \rightarrow H				
SEL, BSY		B	H	H	L				H
$\overline{\text{TIMEOUT}}$	N/A	H	L		L				
DRVBUS [†]	BBSY-/BBSY+, BSEL-/BSEL+, $\overline{\text{TIMEOUT}}$	DRVBUS	H	L	L				
$\overline{\text{TIMEOUT}}$	N/A	Z	H		L				

[†] For these conditions, DRVBUS = BSEL or BBSY and $\overline{\text{TIMEOUT}}$ together.

PARAMETER MEASUREMENT INFORMATION

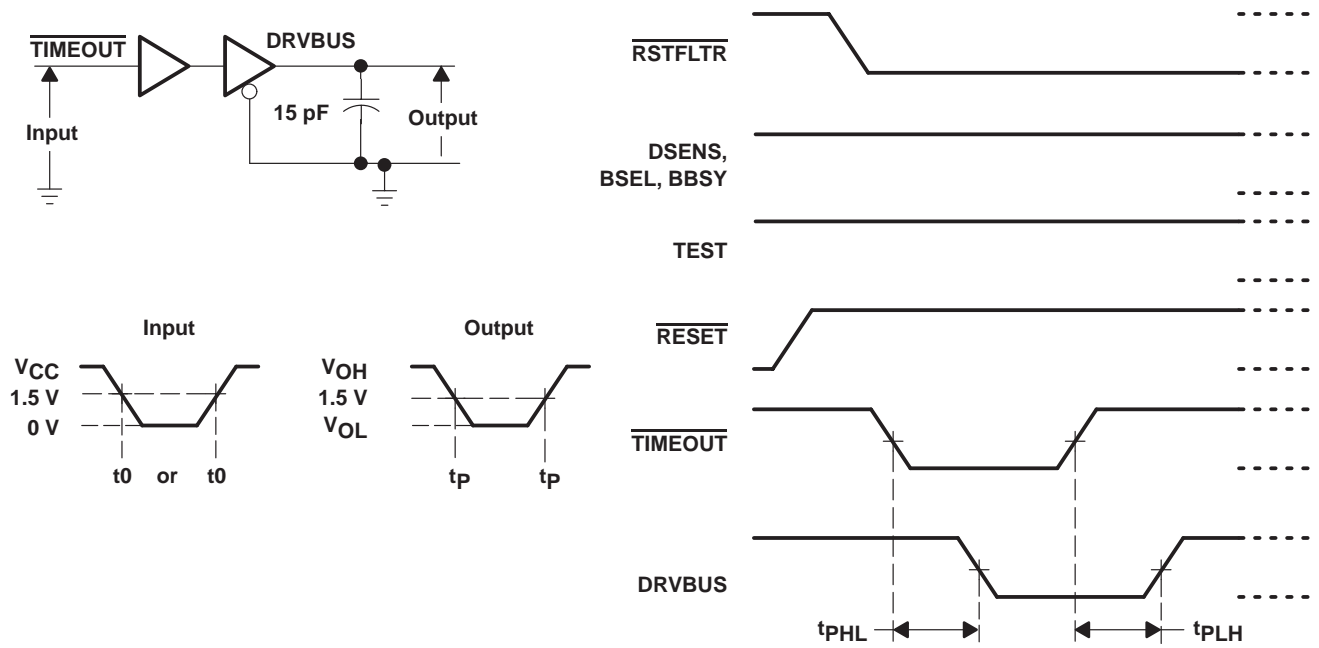
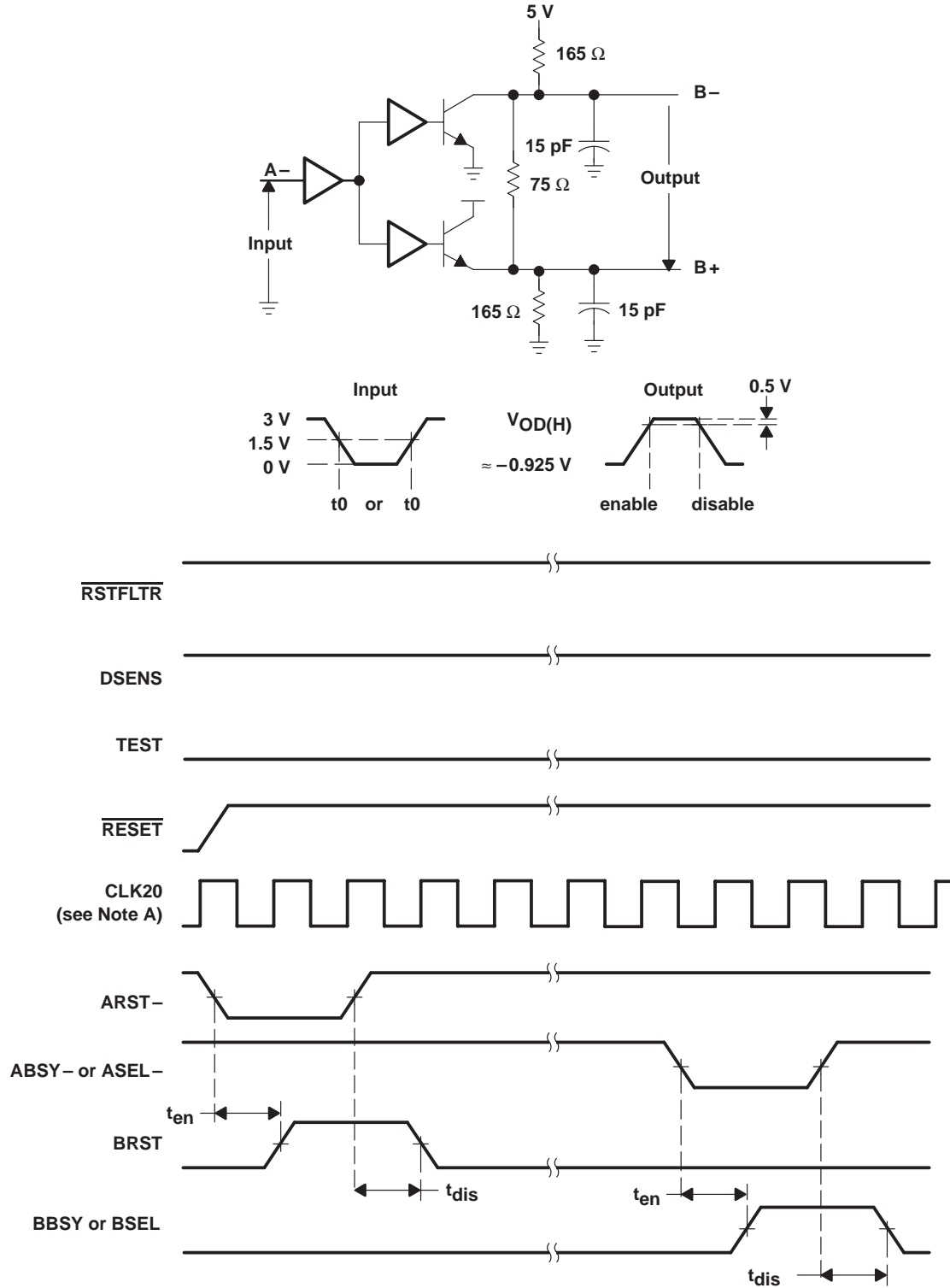

Figure 5. $\overline{\text{TIMEOUT}}$ to DRVBUS Delay Time Test Circuit and Timing Definitions

SN75970B SCSI DIFFERENTIAL CONVERTER-CONTROL

SLLS323A – NOVEMBER 1999 – REVISED JANUARY 2000

PARAMETER MEASUREMENT INFORMATION



NOTE A: These are asynchronous events and do not necessarily align with clock edges.

Figure 6. A-Side to B-Side Enable and Disable Delay Time Test Circuit and Timing Definitions

PARAMETER MEASUREMENT INFORMATION

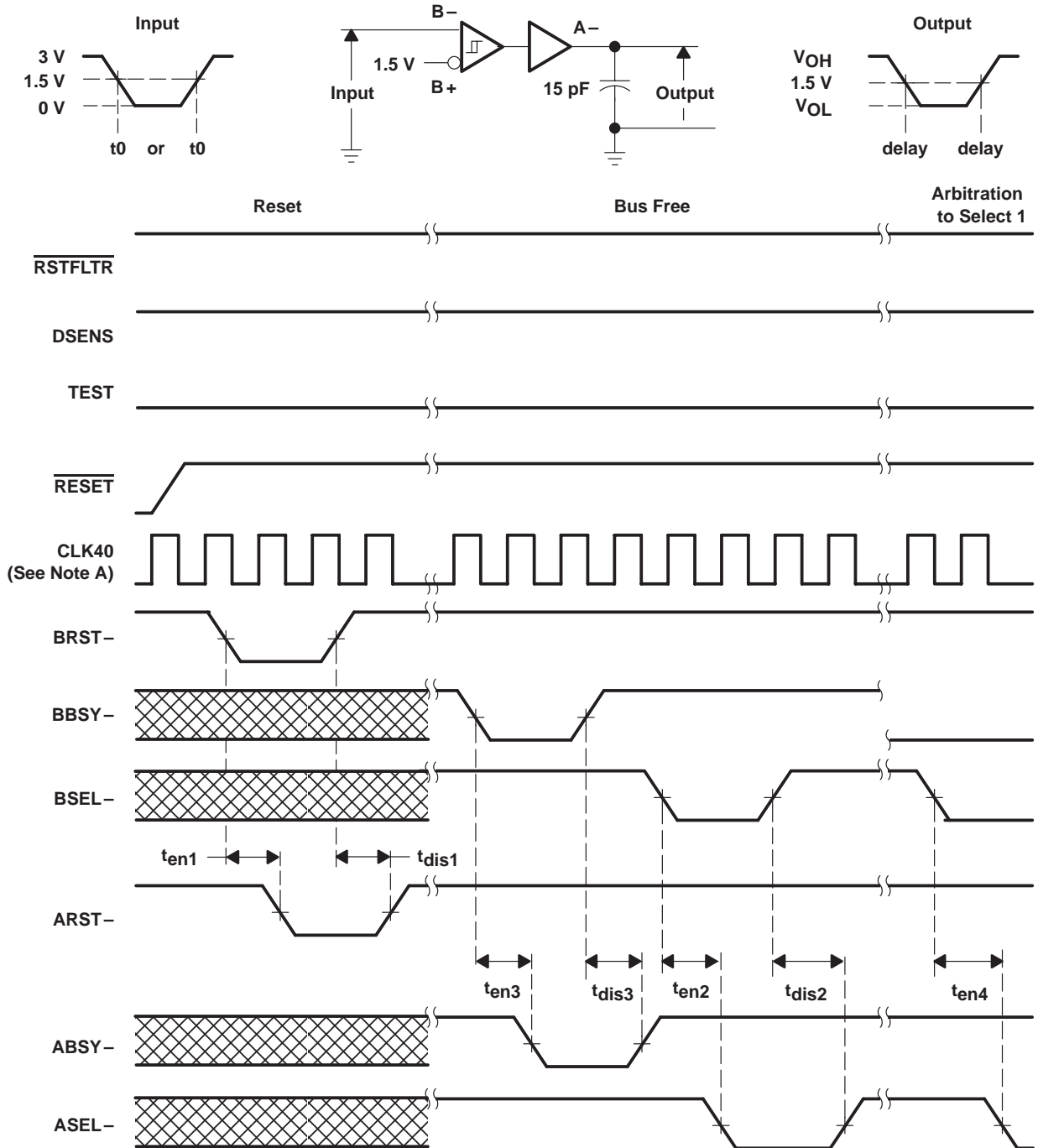

NOTE A: These are asynchronous events and do not necessarily align with clock edges.

Figure 7. B-Side to A-Side Enable and Disable Delay Time Test Circuit and Timing Definitions

SN75970B

SCSI DIFFERENTIAL CONVERTER-CONTROL

SLLS323A – NOVEMBER 1999 – REVISED JANUARY 2000

APPLICATION INFORMATION

To correctly set the direction of the SCSI bus signals, the SN75970B must follow the activity on the bus. An asynchronous, 5-state controller watches the state of all the bus control signals, sets the direction of each control signal as needed, and generates the DRVBUS and SDB outputs to control one or two external SN75971B SCSI differential converter-data devices. The controller never generates the data driven on a bus signal; it only enables the drivers. The clock input implements a 400-ns timer that is not part of the controller itself. Controller-state transitions occur immediately when all the transition conditions are met. Note that the frequency of the supplied clock, either 20 MHz or 40 MHz, must be correct in order to meet the SCSI specifications.

As shown in Figure 8, after reset, the controller begins in the bus free state. In case the controller was attached to an active differential bus, it waits for the SCSI bus free condition, defined as when BBSY and BSEL are deasserted for 400 ns. While waiting for the SCSI bus free condition, the state of BBSY and BSEL passes through to the A side. The A side bus device cannot take part in bus activity during this condition before the SCSI bus free condition. Once SCSI bus free is detected, the SCSI arbitration state is entered. Both ABSY and BBSY are enabled; thus when either signal asserts, both drivers turn on and both signals remain asserted until this state is left. Normally the SCSI arbitration state ends after the winner of arbitration asserts BSEL. This would cause the controller to go to the select 1 state. However, when BSEL is not asserted, a timeout would eventually be detected and cause a reset of the controller. In the select 1 state two latches are open, DSEL_LATCH and RESEL_LATCH. The first latch captures the state of BSEL so that following states can determine whether the arbitration winner was on the A side or B side.



POST OFFICE BOX 655303 • DALLAS, TEXAS 75265

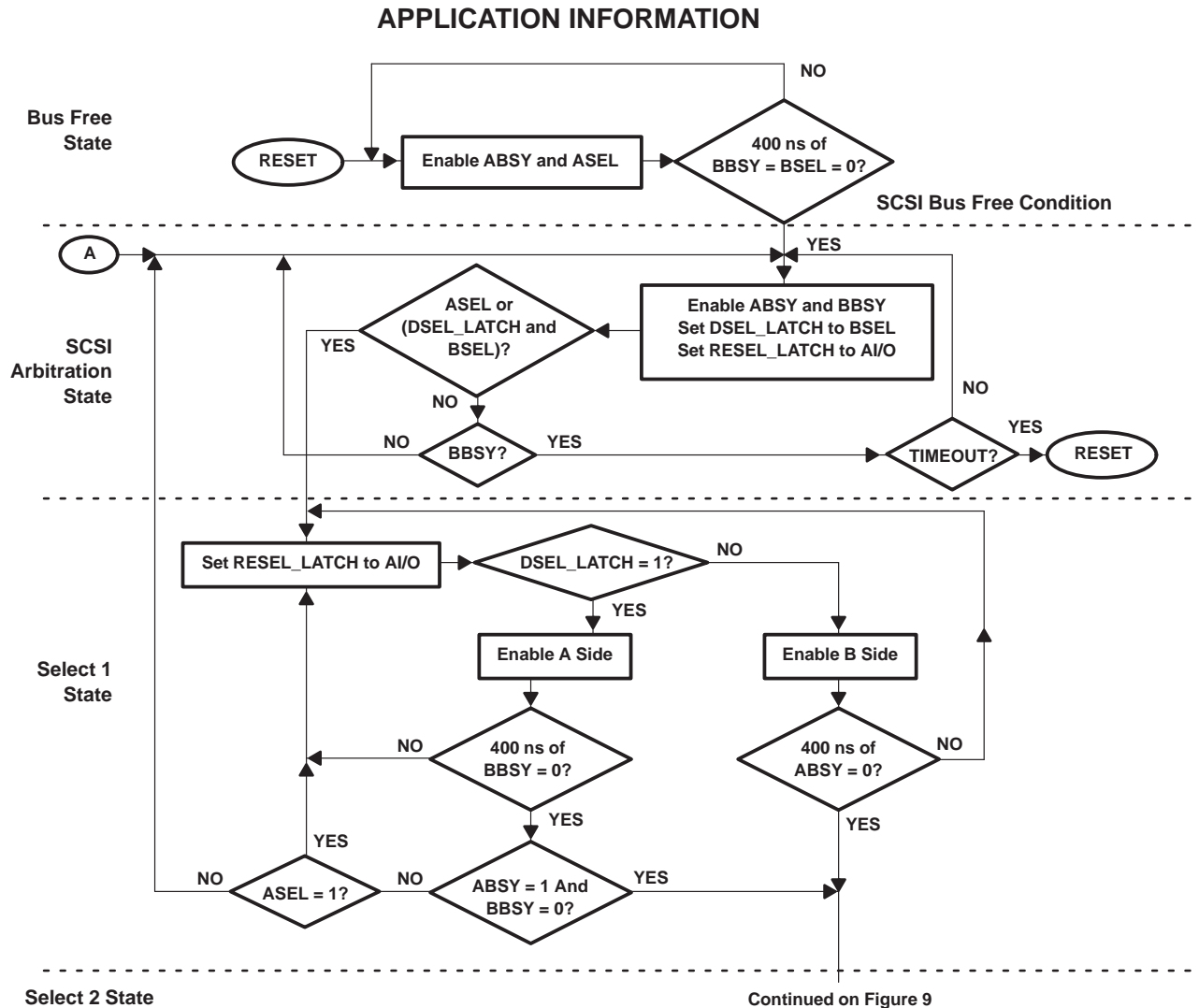

Figure 8. Bus Free, SCSI Arbitration, and Select 1 State Flow Chart

The second latch captures the state of A/I/O, this is true during a reselection phase but not during the selection phase. When the bus is in the selection or reselection phase, the controller enters the select 1 state. There are three possible flows depending on bus events. The first flow is that the SCSI controller on the A side won the arbitration and asserted ASEL. In this event DSEL_LATCH would not be set. The controller passes all signals to the B side and waits for ABSY to deassert for 400 ns, indicating that the A side controller is selecting or reselecting a device on the B side. The object of the A side controller must be on the B side since only one device is allowed on the A side.

The second possible flow is that DSEL_LATCH is set, indicating that the arbitration winner is on the B side, and the winner is selecting or reselecting the device on the A side. The controller passes all signals to the A side and waits for BBSY to deassert for 400 ns. When the A side controller responds by asserting ABSY, the controller detects ABSY asserted and BBSY deasserts and goes to the select 2 state.

SN75970B

SCSI DIFFERENTIAL CONVERTER-CONTROL

SLLS323A – NOVEMBER 1999 – REVISED JANUARY 2000

APPLICATION INFORMATION

The third possible flow is that a device on the B side won the arbitration and is selecting or reselecting another device on the B side. DSEL_LATCH is set, and 400 ns of BBSY is asserted first by the object of the selection or reselection. Since ASEL is still asserted, the controller remains in the select 1 state throughout the selection or reselection. If the BBSY deassertion is missed by the timer, again the controller remains in the select 1 state. Once the transfer state is entered, BBSY is asserted and BSEL is dropped. This again returns the controller to a select 1 state. At the end of the transfer both BBSY and BSEL are deasserted. After the timer limit is reached, the controller goes to the arbitration state for the next bus arbitration.

The controller enters the select 2 state (see Figure 9) during the selection or reselection phases when the initiator and terminator are on the opposite side of SDCC. In this state the RESEL_LATCH is closed, capturing the value of the I/O. When RESEL_LATCH is one, reselection is indicated. When RESEL_LATCH equals zero, a selection is indicated. RESEL_LATCH, along with the DSEL_LATCH, now defines which side the initiator is on and therefore what direction to establish for all the bus signals. The target must be on the other side; if both target and initiator were on the B side, the select 2 state would never be entered.

When the RESEL_LATCH is zero, indicating a selection, the connection is not made. When DSEL_LATCH is one, the initiator is on the B side and the control lines it drives have their A side drivers enabled. These terminals are the initiator group of ACK and ATN along with SEL. The other terminals are driven by the target and have the B side drivers enabled. They are the target group of REQ, MSG, C/D, and I/O, along with BSY. When DSEL_LATCH is zero the connection is reversed. Since transfer states are not started, DRVBUS is set to 1, indicating that the data transceiver chips should not take their direction control from SDB and should be actively negated. SDB is generated from I/O and is the bus signal that determines data transfer direction. In this case it indicates the selection phase, the controller immediately transfers to the transfer state, where exactly the same actions are done.

When the RESEL_LATCH is 1 indicating a reselection, there are one or more actions before information states can be entered. When the target reselects the initiator, the initiator responds by asserting BSY. Once the connection is made, the assertion of BSY must be changed over to the target, and the controller must reverse the BSY driver direction. It does this when SEL deasserts by transferring to the transfer state where the BSY direction is reversed. In the select 2 state all the control line directions are set as appropriate, except that DRVBUS is not yet asserted. In the transfer state DRVBUS is set as well.

The controller remains in the transfer state during all other SCSI states. When a bus free state is detected, it goes back to the arbitration state to wait for the next activity. Note that after BBSY and BSEL deassert, the controller continues to actively drive the control lines and the data lines through DRVBUS until 400 ns of continuous deassertion is detected. The drivers are turned off only when the state change occurs.

Figure 10 shows a typical system configuration. The timeout function used in the arbitration state is implemented with a resistor and capacitor connected to the $\overline{\text{TIMEOUT}}$ terminal. During reset and whenever the timer is not in use, the terminal is driven to V_{CC} . The timer starts when the driver turns off, allowing the capacitor to charge and the $\overline{\text{TIMEOUT}}$ terminal to drop to ground. When V_{IT-} is reached, the driver turns on, discharging the capacitor and returning $\overline{\text{TIMEOUT}}$ to V_{CC} . A timeout event is declared after the driver turns back on and $\overline{\text{TIMEOUT}}$ exceeds V_{IT+} .

RST can be asserted on either the A or B side, and is driven to the other side. The drive to the other side is controlled by a bidirectional latch. When one side asserts, the other side is asserted and a latch is set to that direction. When the first side deasserts, the driver turns off, but the direction is held until both sides are deasserted. Only then can the direction change.



POST OFFICE BOX 655303 • DALLAS, TEXAS 75265

APPLICATION INFORMATION

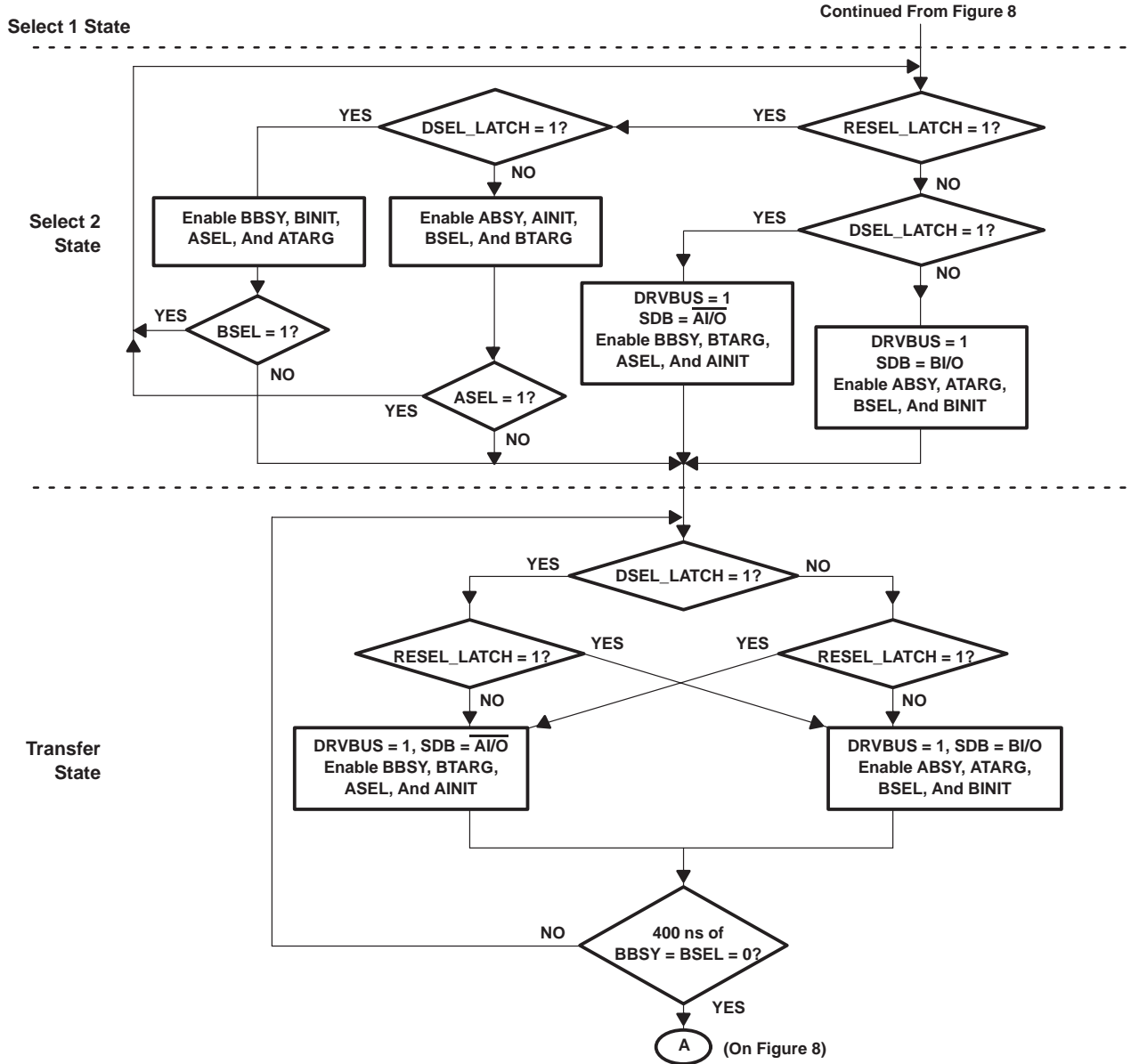

Figure 9. SCSI Select 1, Select 2, and Transfer State Flow Chart

SN75970B SCSI DIFFERENTIAL CONVERTER-CONTROL

SLLS323A – NOVEMBER 1999 – REVISED JANUARY 2000

APPLICATION INFORMATION

The SCSI bus signal RST does not directly clear SDCC internal logic. Instead, the RSTFLTR terminal can be connected as ARST—so that a bus reset clears SDCC. RSTFLTR clears the internal controller but does not clear the RST bidirectional latch. By connecting these terminal externally through a RC filter as shown in Figure 8, noise pulses on the bus may be filtered as recommended by the SCSI-2 specification.

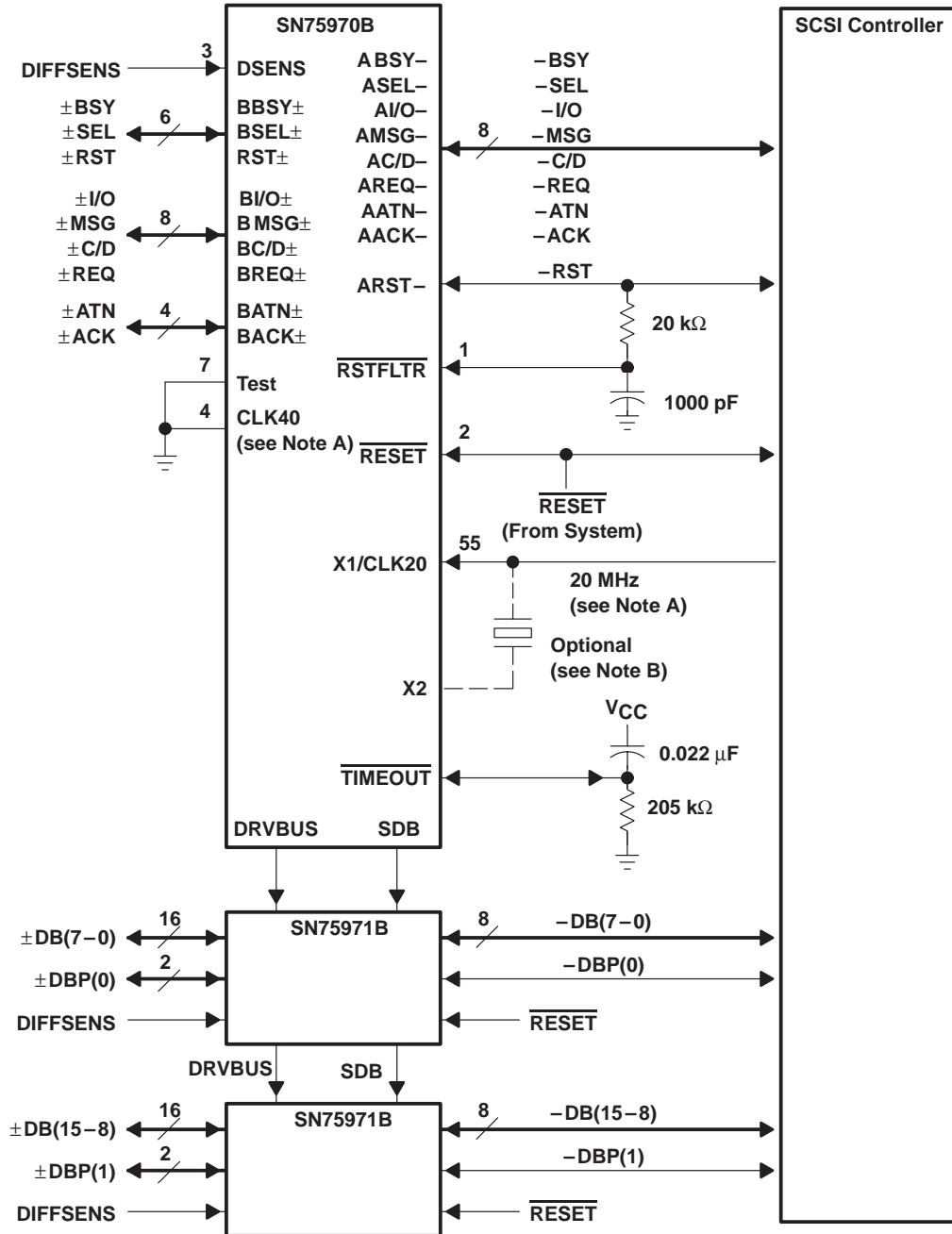

- NOTES: A. When using the 40 MHz clock input, X1 must be connected to V_{CC}.
 B. The oscillator cell of the SN75970B is for a series-resonant crystal and needs approximately 10 pF (including fixture capacitance) from X1 and X2 to ground in order to function.

Figure 10. Typical Application of the SN75970B and SN75971B



POST OFFICE BOX 655303 • DALLAS, TEXAS 75265

MECHANICAL INFORMATION

DGG (R-PDSO-G**)

PLASTIC SMALL-OUTLINE PACKAGE

48 PIN SHOWN

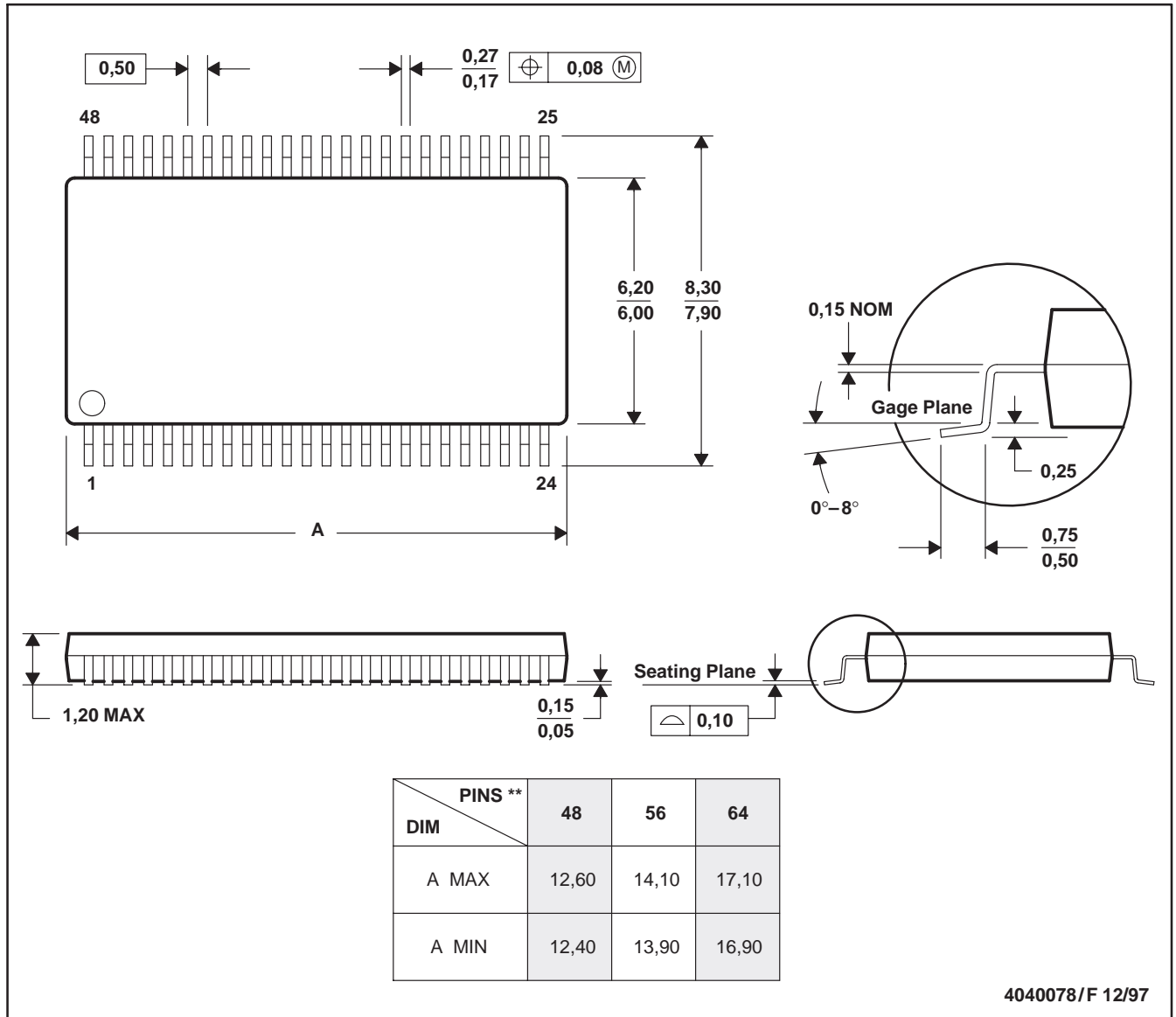

- NOTES: A. All linear dimensions are in millimeters.
 B. This drawing is subject to change without notice.
 C. Body dimensions do not include mold protrusion not to exceed 0,15.
 D. Falls within JEDEC MO-153

SN75970B SCSI DIFFERENTIAL CONVERTER-CONTROL

SLLS323A – NOVEMBER 1999 – REVISED JANUARY 2000

MECHANICAL INFORMATION

DL (R-PDSO-G**)

PLASTIC SMALL-OUTLINE PACKAGE

48 PIN SHOWN

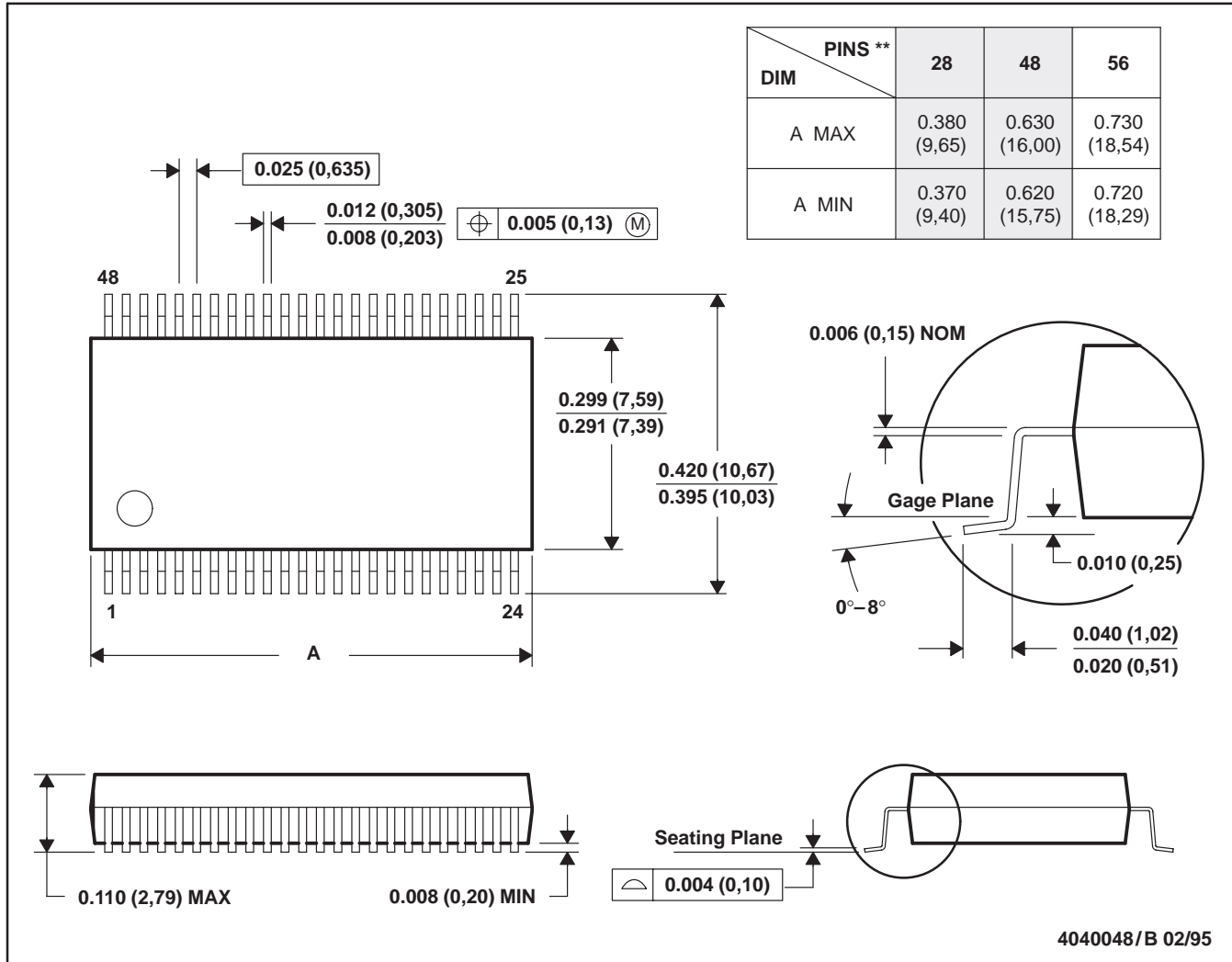

- NOTES: A. All linear dimensions are in inches (millimeters).
 B. This drawing is subject to change without notice.
 C. Body dimensions do not include mold flash or protrusion not to exceed 0.006 (0,15).

PACKAGING INFORMATION

Orderable Device	Status ⁽¹⁾	Package Type	Package Drawing	Pins	Package Qty	Eco Plan ⁽²⁾	Lead/Ball Finish	MSL Peak Temp ⁽³⁾
SN75970B1DL	ACTIVE	SSOP	DL	56	20	Green (RoHS & no Sb/Br)	CU NIPDAU	Level-2-260C-1 YEAR
SN75970B1DLG4	ACTIVE	SSOP	DL	56	20	Green (RoHS & no Sb/Br)	CU NIPDAU	Level-2-260C-1 YEAR
SN75970B2DGG	ACTIVE	TSSOP	DGG	56	35	Green (RoHS & no Sb/Br)	CU NIPDAU	Level-2-260C-1 YEAR
SN75970B2DGGG4	ACTIVE	TSSOP	DGG	56	35	Green (RoHS & no Sb/Br)	CU NIPDAU	Level-2-260C-1 YEAR
SN75970B2DGGGR	ACTIVE	TSSOP	DGG	56	2000	Green (RoHS & no Sb/Br)	CU NIPDAU	Level-2-260C-1 YEAR
SN75970B2DGGRG4	ACTIVE	TSSOP	DGG	56	2000	Green (RoHS & no Sb/Br)	CU NIPDAU	Level-2-260C-1 YEAR
SN75970B2DL	ACTIVE	SSOP	DL	56	20	Green (RoHS & no Sb/Br)	CU NIPDAU	Level-2-260C-1 YEAR
SN75970B2DLG4	ACTIVE	SSOP	DL	56	20	Green (RoHS & no Sb/Br)	CU NIPDAU	Level-2-260C-1 YEAR
SN75970BDGG	OBSOLETE	TSSOP	DGG	56		TBD	Call TI	Call TI
SN75970BDL	OBSOLETE	SSOP	DL	56		TBD	Call TI	Call TI

⁽¹⁾ The marketing status values are defined as follows:

ACTIVE: Product device recommended for new designs.

LIFEBUY: TI has announced that the device will be discontinued, and a lifetime-buy period is in effect.

NRND: Not recommended for new designs. Device is in production to support existing customers, but TI does not recommend using this part in a new design.

PREVIEW: Device has been announced but is not in production. Samples may or may not be available.

OBSOLETE: TI has discontinued the production of the device.

⁽²⁾ Eco Plan - The planned eco-friendly classification: Pb-Free (RoHS), Pb-Free (RoHS Exempt), or Green (RoHS & no Sb/Br) - please check <http://www.ti.com/productcontent> for the latest availability information and additional product content details.

TBD: The Pb-Free/Green conversion plan has not been defined.

Pb-Free (RoHS): TI's terms "Lead-Free" or "Pb-Free" mean semiconductor products that are compatible with the current RoHS requirements for all 6 substances, including the requirement that lead not exceed 0.1% by weight in homogeneous materials. Where designed to be soldered at high temperatures, TI Pb-Free products are suitable for use in specified lead-free processes.

Pb-Free (RoHS Exempt): This component has a RoHS exemption for either 1) lead-based flip-chip solder bumps used between the die and package, or 2) lead-based die adhesive used between the die and leadframe. The component is otherwise considered Pb-Free (RoHS compatible) as defined above.

Green (RoHS & no Sb/Br): TI defines "Green" to mean Pb-Free (RoHS compatible), and free of Bromine (Br) and Antimony (Sb) based flame retardants (Br or Sb do not exceed 0.1% by weight in homogeneous material)

⁽³⁾ MSL, Peak Temp. -- The Moisture Sensitivity Level rating according to the JEDEC industry standard classifications, and peak solder temperature.

Important Information and Disclaimer: The information provided on this page represents TI's knowledge and belief as of the date that it is provided. TI bases its knowledge and belief on information provided by third parties, and makes no representation or warranty as to the accuracy of such information. Efforts are underway to better integrate information from third parties. TI has taken and continues to take reasonable steps to provide representative and accurate information but may not have conducted destructive testing or chemical analysis on incoming materials and chemicals. TI and TI suppliers consider certain information to be proprietary, and thus CAS numbers and other limited information may not be available for release.

In no event shall TI's liability arising out of such information exceed the total purchase price of the TI part(s) at issue in this document sold by TI to Customer on an annual basis.

TAPE AND REEL INFORMATION



A0	Dimension designed to accommodate the component width
B0	Dimension designed to accommodate the component length
K0	Dimension designed to accommodate the component thickness
W	Overall width of the carrier tape
P1	Pitch between successive cavity centers

QUADRANT ASSIGNMENTS FOR PIN 1 ORIENTATION IN TAPE

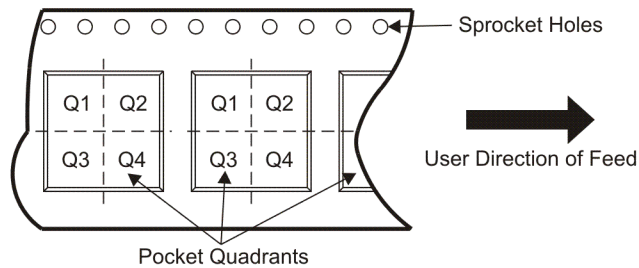

*All dimensions are nominal

Device	Package Type	Package Drawing	Pins	SPQ	Reel Diameter (mm)	Reel Width W1 (mm)	A0 (mm)	B0 (mm)	K0 (mm)	P1 (mm)	W (mm)	Pin1 Quadrant
SN75970B2DGGR	TSSOP	DGG	56	2000	330.0	24.4	8.6	15.6	1.8	12.0	24.0	Q1

TAPE AND REEL BOX DIMENSIONS



*All dimensions are nominal

Device	Package Type	Package Drawing	Pins	SPQ	Length (mm)	Width (mm)	Height (mm)
SN75970B2DGGR	TSSOP	DGG	56	2000	346.0	346.0	41.0

IMPORTANT NOTICE

Texas Instruments Incorporated and its subsidiaries (TI) reserve the right to make corrections, modifications, enhancements, improvements, and other changes to its products and services at any time and to discontinue any product or service without notice. Customers should obtain the latest relevant information before placing orders and should verify that such information is current and complete. All products are sold subject to TI's terms and conditions of sale supplied at the time of order acknowledgment.

TI warrants performance of its hardware products to the specifications applicable at the time of sale in accordance with TI's standard warranty. Testing and other quality control techniques are used to the extent TI deems necessary to support this warranty. Except where mandated by government requirements, testing of all parameters of each product is not necessarily performed.

TI assumes no liability for applications assistance or customer product design. Customers are responsible for their products and applications using TI components. To minimize the risks associated with customer products and applications, customers should provide adequate design and operating safeguards.

TI does not warrant or represent that any license, either express or implied, is granted under any TI patent right, copyright, mask work right, or other TI intellectual property right relating to any combination, machine, or process in which TI products or services are used. Information published by TI regarding third-party products or services does not constitute a license from TI to use such products or services or a warranty or endorsement thereof. Use of such information may require a license from a third party under the patents or other intellectual property of the third party, or a license from TI under the patents or other intellectual property of TI.

Reproduction of TI information in TI data books or data sheets is permissible only if reproduction is without alteration and is accompanied by all associated warranties, conditions, limitations, and notices. Reproduction of this information with alteration is an unfair and deceptive business practice. TI is not responsible or liable for such altered documentation. Information of third parties may be subject to additional restrictions.

Resale of TI products or services with statements different from or beyond the parameters stated by TI for that product or service voids all express and any implied warranties for the associated TI product or service and is an unfair and deceptive business practice. TI is not responsible or liable for any such statements.

TI products are not authorized for use in safety-critical applications (such as life support) where a failure of the TI product would reasonably be expected to cause severe personal injury or death, unless officers of the parties have executed an agreement specifically governing such use. Buyers represent that they have all necessary expertise in the safety and regulatory ramifications of their applications, and acknowledge and agree that they are solely responsible for all legal, regulatory and safety-related requirements concerning their products and any use of TI products in such safety-critical applications, notwithstanding any applications-related information or support that may be provided by TI. Further, Buyers must fully indemnify TI and its representatives against any damages arising out of the use of TI products in such safety-critical applications.

TI products are neither designed nor intended for use in military/aerospace applications or environments unless the TI products are specifically designated by TI as military-grade or "enhanced plastic." Only products designated by TI as military-grade meet military specifications. Buyers acknowledge and agree that any such use of TI products which TI has not designated as military-grade is solely at the Buyer's risk, and that they are solely responsible for compliance with all legal and regulatory requirements in connection with such use.

TI products are neither designed nor intended for use in automotive applications or environments unless the specific TI products are designated by TI as compliant with ISO/TS 16949 requirements. Buyers acknowledge and agree that, if they use any non-designated products in automotive applications, TI will not be responsible for any failure to meet such requirements.

Following are URLs where you can obtain information on other Texas Instruments products and application solutions:

Products

Amplifiers	amplifier.ti.com
Data Converters	dataconverter.ti.com
DSP	dsp.ti.com
Clocks and Timers	www.ti.com/clocks
Interface	interface.ti.com
Logic	logic.ti.com
Power Mgmt	power.ti.com
Microcontrollers	microcontroller.ti.com
RFID	www.ti-rfid.com
RF/IF and ZigBee® Solutions	www.ti.com/lprf

Applications

Audio	www.ti.com/audio
Automotive	www.ti.com/automotive
Broadband	www.ti.com/broadband
Digital Control	www.ti.com/digitalcontrol
Medical	www.ti.com/medical
Military	www.ti.com/military
Optical Networking	www.ti.com/opticalnetwork
Security	www.ti.com/security
Telephony	www.ti.com/telephony
Video & Imaging	www.ti.com/video
Wireless	www.ti.com/wireless

Mailing Address: Texas Instruments, Post Office Box 655303, Dallas, Texas 75265
Copyright © 2008, Texas Instruments Incorporated